

CulinArt



CulinArt



The office kitchen - the heart of the company, where everyday conversations come alive.

CulinArt

CulinArt office kitchen combines modern design with exceptional functionality. Thanks to a variety of sizes and a wide range of available front and top colors and finishes, CulinArt offers cutting-edge and highly practical design solutions.

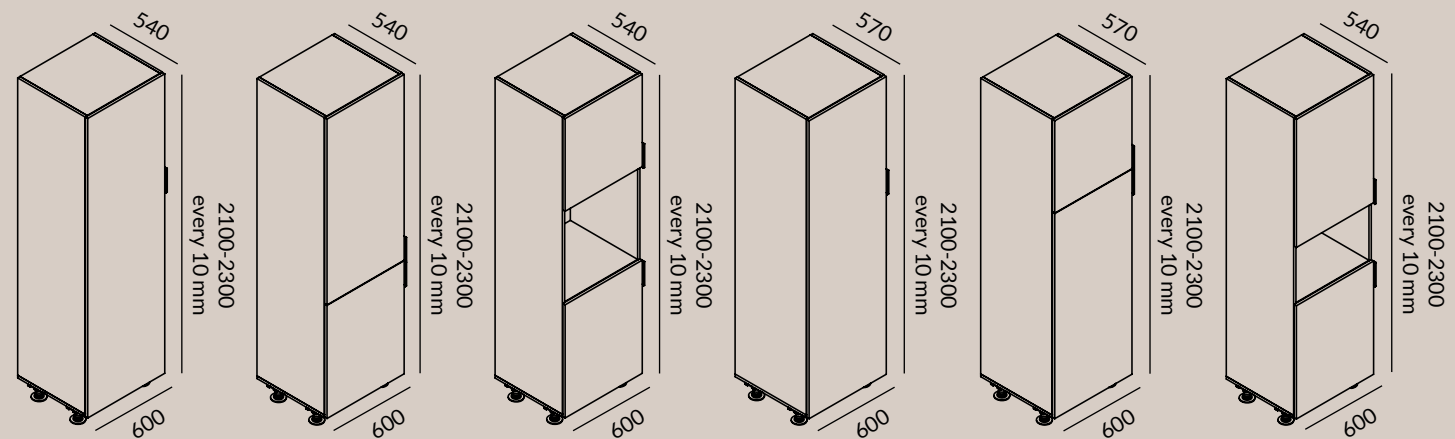
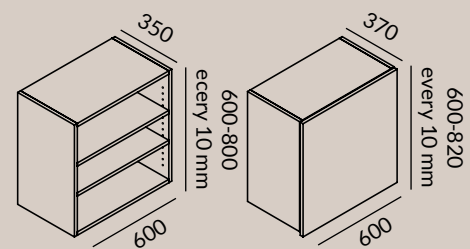
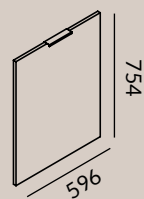
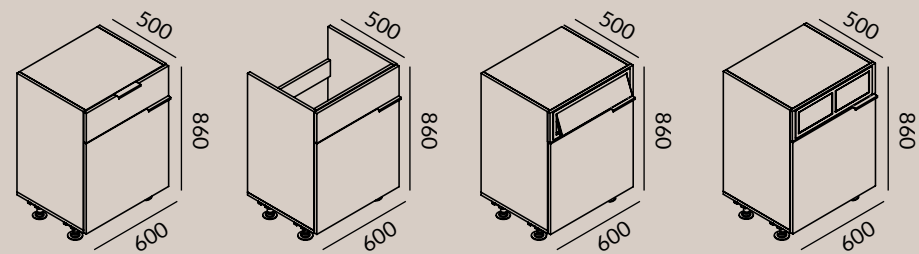
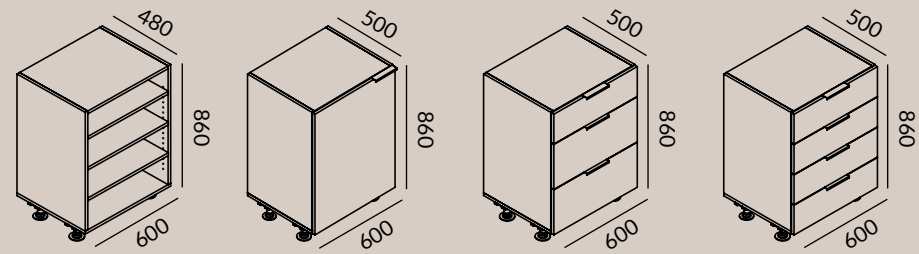

CulinArt

Faucets



FRANKE

Microwave ovens



BOSCH and SIEMENS

Sinks



FRANKE

Dishwashers



BOSCH and SIEMENS

Refrigerators



BOSCH and SIEMENS

Drawers



BLUM

CulinArt

Kitchen top



STANDARD front



TREND front



CulinArt

CulinArt



EN | Whether your office kitchen is small or it is integrated into an open-plan space, CulinArt brings solutions to suit every setting.

PL | Niezależnie od tego, czy to niewielka przestrzeń kuchenna w biurze, czy też kuchnia zintegrowana z otwartą przestrzenią, CulinArt zapewnia rozwiązania dostosowane do każdej sytuacji.

DE | Ob es sich nun um eine kleine Büroküche oder um eine in einen offenen Raum integrierte Küche handelt - CulinArt bietet passende Lösungen für jedes Küchenkonzept.

FR | Que ce soit pour un petit espace de cuisine dans un bureau ou une cuisine intégrée à un espace ouvert, CulinArt propose des solutions adaptées à chaque situation.

Culin Art



CulinArt

EN | Wall cabinets offer plenty of storage space for cups, plates and bowls. They are easily accessible over the worktop. Base cabinets are perfect for cutlery, heavier dishes and food. These kitchen solutions keep the space tidy and help employees enjoy their break time.

PL | Szafki górne oferują sporo przestrzeni na przechowywanie filiżanek, talerzy i misek, dzięki czemu są one łatwo dostępne nad blatem roboczym. Szafki dolne to doskonała przestrzeń na sztućce, cięższe naczynia, produkty spożywcze. Takie rozwiązania kuchenne gwarantują porządek, a pracownicy mogą cieszyć się miłą atmosferą w strefie przerw.

DE | Die Oberschränke bieten viel Stauraum für Tassen, Teller und Schüsseln und sind über der Arbeitsplatte leicht zugänglich. In den Unterschränken können Besteck, größeres Geschirr und Lebensmittel aufbewahrt werden. Solche Küchenlösungen sorgen für Ordnung und lassen die Mitarbeiter eine gemütliche Atmosphäre im Pausenbereich genießen.

FR | Les armoires du haut offrent beaucoup d'espace de rangement pour les tasses, assiettes et bols, ce qui les rend facilement accessibles au-dessus du plan de travail. Les armoires du bas offrent un espace idéal pour les couverts, les ustensiles plus lourds et les produits alimentaires. Ces solutions de cuisine garantissent l'ordre, et les employés peuvent profiter d'une atmosphère agréable dans la zone de pause.



Culin Art



Culin Art



EN | To complement your office kitchen, canteen or dining room opt for our tables, which are available in multiple sizes and in many interesting colors.

PL | Dopelnieniem biurowych mebli kuchennych są stoły do stołówki czy jadalni dostępne w kilku rozmiarach oraz w wielu ciekawych kolorach.

DE | Eine praktische Ergänzung für die Küchenkollektion bieten die Tische für Kantinen und Speisesäle, die in verschiedenen Größen und in vielen interessanten Farben erhältlich sind.

FR | Pour compléter les meubles de cuisine de bureau, des tables de salle à manger ou de cantine sont disponibles en plusieurs tailles et dans de nombreuses couleurs intéressantes.

CulinArt



Culin Art

